

# Safety Switch Reset

1. Lift the gold /red box lid off, slide to two side panels up.

2. Locate the safety switch in the Gold/ Red Box attached to the bottom plate.

3. If the safety switch is up **(A)**, remove cotton ball inside that is wet (expanded), **thoroughly dry all water** on the base plate and the **wet area (B)**, replace with a new cotton ball **(C)**, and push the switch back down **(D)**.

4. Use a flash light to check for leaks. If no leaks are found, then proceed with normal use **(E)**.

**A** : switch in up position

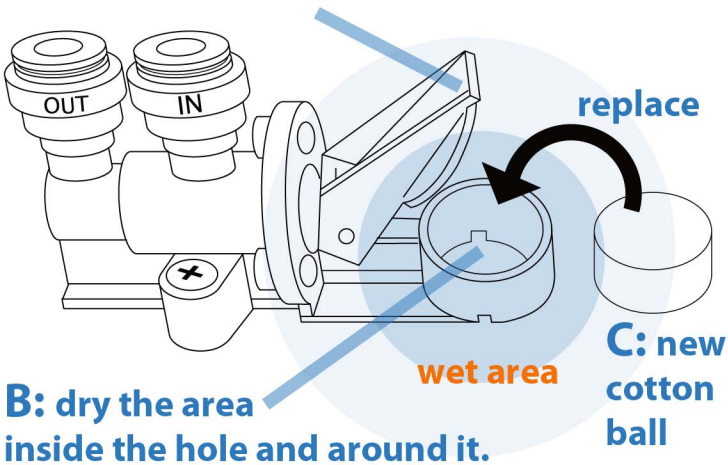

**D**: push the switch down.

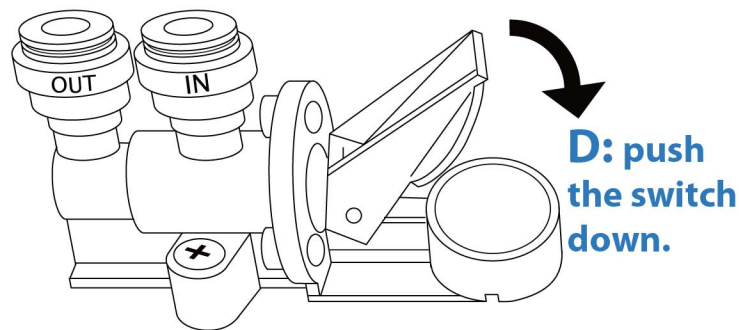

**E**: Normal Use Position

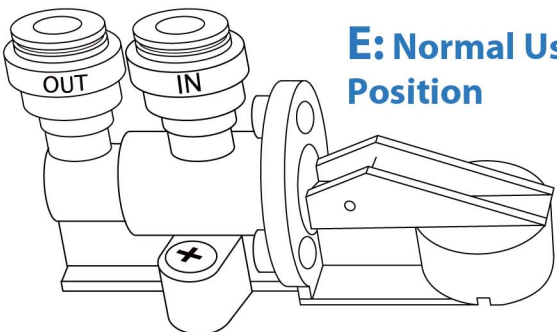

If there are more leaks, flip the switch back up **(A)** to shut off the water, contact us at 1-888-850-3743, or report the issue in your app or springaqua.com "login", and customer service team will contact you shortly.

Extra cotton balls are located with the accessory kit from the initial box, more cotton balls can be purchased through our accessories department.